

INPUT MODULE INP08



Figure 1 : Input module INP08

1. Product Description

Module for DIN-rail, for connecting external contacts such as solar/wind detector, motion detector, door switches and push buttons. Eight optical isolated inputs are provided, which must be potential-free.

The INP08 can have 8 optically disconnected potential-free inputs. The maximum length of each input is 200 meters. The cable type or its section is irrelevant.

The input contacts can be selected and set using the Qbus configuration software:

- Push button = button that is open when inactive – only active when pushed shortly (e.g. doorbell).
- Normal open = contact that is open when inactive.
- Normal closed = contact that is closed when inactive.
- Switch = when a single-pole conventional switch is connected to the input.

WARNING: ALWAYS USE NORMAL OPEN OR NORMAL CLOSE CONTACTS WHEN INPUTS ARE CONNECTED THAT GIVE AN EXTENDED CONTACT (E.G. MAGNETIC WINDOW-CONTACT, SMOKE OR MOTION DETECTOR,...). THESE INPUTS ARE ON FOR AN EXTENDED PERIOD OF TIME. ONLY USE THE “PUSH BUTTON” SETTING FOR SHORT CONTACTS.

An INP08 can control 8 outputs, 8 scenes or 8 x 16 scenes (via the sequence function).

For each input a LED shows whether the connected contact is open (LED is OFF) or closed (LED is illuminated).

The INP08 has an 230Vac 50 Hz power supply to supply the internal electronics. A bipolar automatic fuse of a maximum of 6A must be placed on the mains power.

Each module has 1 unique serial number for programming via the Qbus configuration software.

ALWAYS USE POTENTIAL-FREE CONTACTS!
NEVER CONNECT OR DISCONNECT MODULES WHILE THE BUS IS ENERGIZED!

2. Safety Instructions

Read the complete manual before carrying out the installation and activating the system.



WARNING

- The device must be mounted and commissioned by an authorized electrician in accordance with the country-specific regulations.
- This device is exclusively suitable for DIN-rail mounting EN 50022. It must be mounted in a fireproof, closed distribution board with ventilation holes.
- A safety disconnection of the device must be possible. Before carrying out the installation the INP08 should be de-energized.
- Never connect an AC or DC voltage to an input for a potential-free contact. This will damage the input module.
- The device must not be opened. The guarantee provisions will be void when the module has been opened.
- Electrical shock when live parts are touched.

3. Mounting and wiring

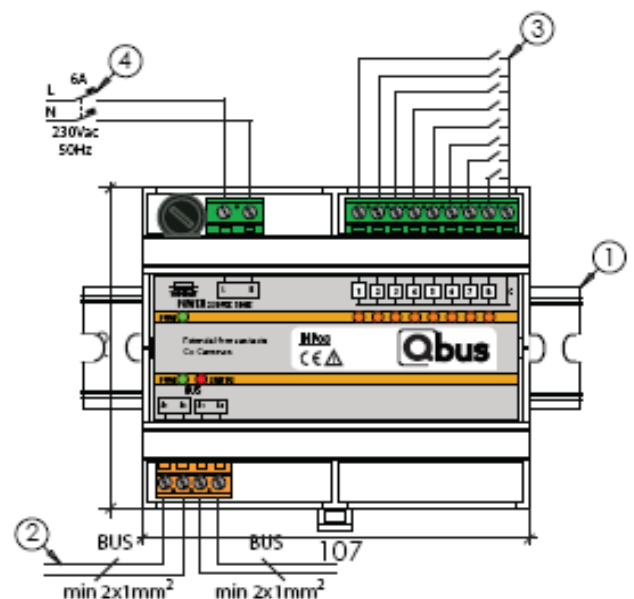

Figure 2 : Connection example for mains voltage and inputs

INPUT MODULE INP08

FITTING ①:

Snap device onto DIN rail to DIN EN 50022.

BUS WIRING ② :

It is recommended to use the Qbus cable or any other cable with minimum 2 x 1mm² conductors as a bus lead. The green protected EIB wire is also allowed when the conductors are guided per 2 in order to obtain a section of minimum 2 x 1mm².

IMPORTANT : THE BUS CABLE SHOULD BE SHIELDED AND GROUNDED! THE GROUNDING SHOULD BE CONNECTED TO THE OVERALL GROUNDING OF THE BUILDING

INPUT CIRCUITS ③ :

Connect the inputs according the connection example (figure 2). Conductor cross section : maximum 1,5mm². Remove approx 7mm of insulation from the wire and screw it into the terminals IN1 – IN8.

POWER SUPPLY ④ :

A bipolar automatic fuse of a maximum of 6A must be placed on the mains power 230Vac.

Conductor cross section : maximum 1,5mm².

Remove approx 7mm of insulation from the wire and screw it into the terminals Ph-N.

WARNING :

BEFORE WORKING ON THE DEVICE DISCONNECT THE SUPPLY VOLTAGE.

LED INDICATION ⑤ :

Green leds: power supply.

Red led: will light up two seconds during start-up and afterwards when programming the module.

Orange leds 1-8: when the contact is connected (closed).

4. Technical Data

GENERAL SPECIFICATIONS :

- Power supply : 230Vac +-10%, 50 Hz - maximum protection 6A/2P
- Insulation voltage : 3 KV tested
- Characteristic consumption : 2.3VA
- Ambient temperature :
Working temp. range : 10°C to 50°C
Storage temp. range : -10°C to 60°C
- Maximum humidity : 93%, no moisture condensation
- Bus load : 10mA at nominal 13,8V
- Internal fuse : 500mA single-phase
- Max installation altitude : 2.000m

INPUTS :

- IN1 – IN8 : 8 potential-free single contacts
- Input signal delay :
- when closing the contact : max 100ms
- after opening the contact : max 100ms
- Input function : to be set by Qbus Configuration Software (System Manager).

PHYSICAL SPECIFICATIONS

- Housing : Plastic, self-extinguishing acc. to UL94-V0
- Protection Degree : IP20, EN 60529
- Installation : rapid mounting on DIN-RAIL, width 6 modules
- Dimensions (HxWxL) : 62mm x 89mm x 107mm
- Weight : approx. 0,274 kg

ELECTRICAL SAFETY

- Bus : 13,8VDC safety extra low voltage (according EN 60950 – 1 : 2006)
- Insulation voltage : 3 kVac tested and certified (50Hz, 1min)
- Non-toxic WEEE/RoHS compliant

CE

- Complies with the EMC regulations and low voltage regulations. The device complies with HBES – EN 50090-2-2 and EN 60950 – 1 : 2006.

5. Dimension Diagram

Dimensions in mm.

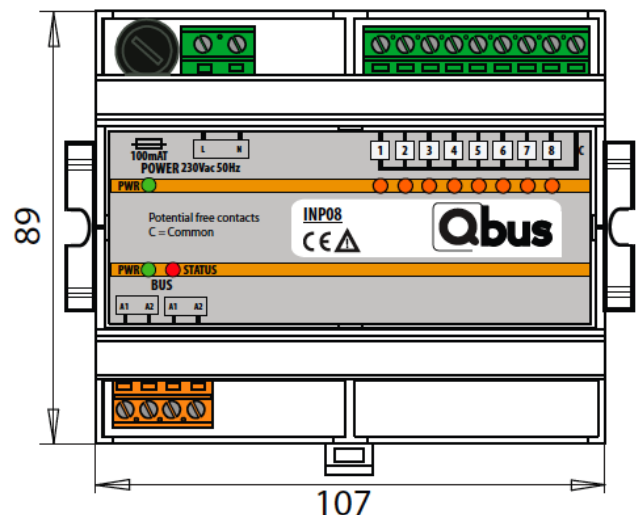

INPUT MODULE INP08

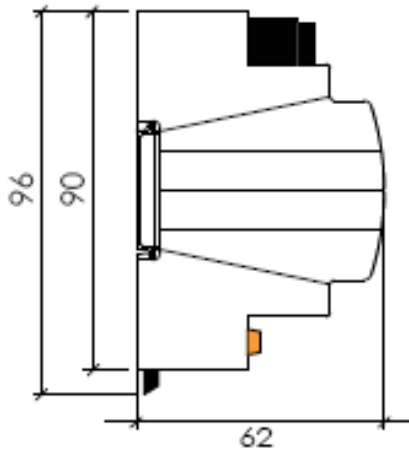

Width = 6 modules.
1 Module = 17mm.

6. Guarantee provisions

Period of guarantee : 2 years from date of delivery.
Guarantee will not be accepted if the device has been opened!
Any faulty devices should be send postage-free with a description of the defect to our central customer service office :

QBUS N.V.
Joseph Cardijnstraat 19
9420 Erpe-Mere
Belgium
T +32 53 60 72 10
F +32 53 60 72 19
Email : support@qbus.be